

Dimensions:

1450 mm (l) x 550 mm (d) x 850 mm (h)

Grilling area | Zone de grillade: 1275mm x 407mm

Weight | Poids: 205 kg

Thermal Flow | Débit thermique: 30,80kw

Type | Tipo: A

Category | Catégorie: II_{2H3+}

Voltage | Tension: 230 V

Electric Power | Puissance électrique: 44 w

Butane gas | Gaz Butane

Pressure | Pression - 28-30 mbar

Consumption | Consommation - 2,5 kg/h

Propane gas | Gaz propane

Pressure | Pression - 37 mbar

Consumption | Consommation - 2,5 kg/h

Natural gas | Gaz naturel

Pressure | Pression - 20 mbar

Consumption | Consommation - 3,3 m³/h

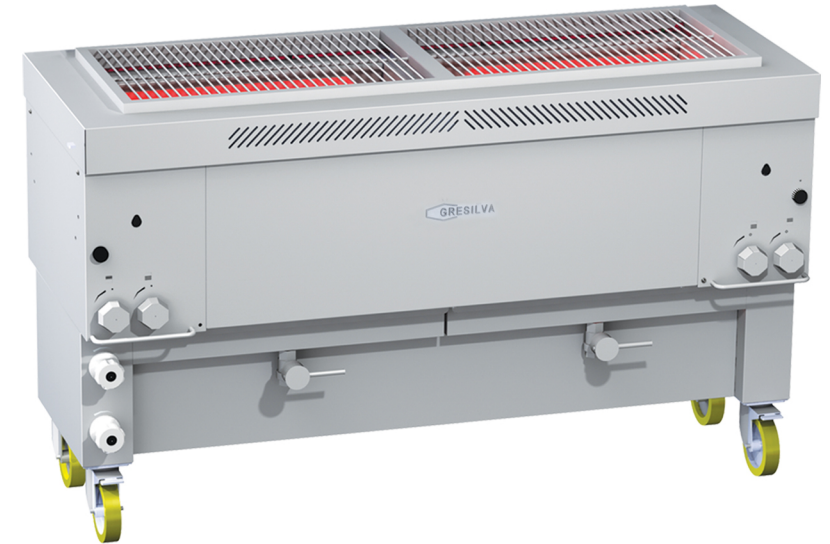

support with extra grids
support avec grilles extra

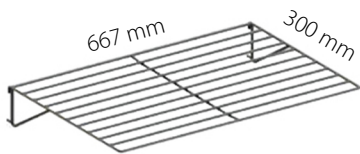

GRE.F2.P71
extra grid
extra grill



GRE.F5.P70
support grids
porte-grille



GRE.F5.P72
Pack



Scraper
Grattoir



Line | Ligne **5**

Horizontal Grill | Gril Horizontal
mod GHPI **F5/1450**



www.gresilva.com

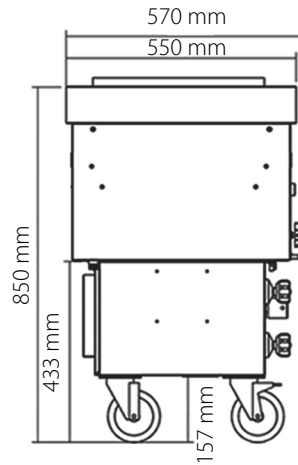
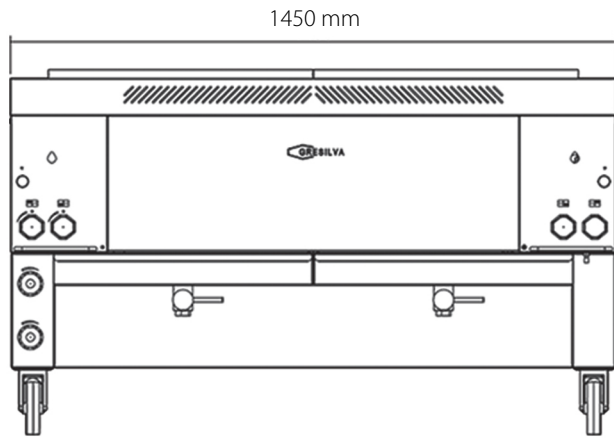

*protective plate for ceramic tiles
plaque de protection pour carreaux de céramique*

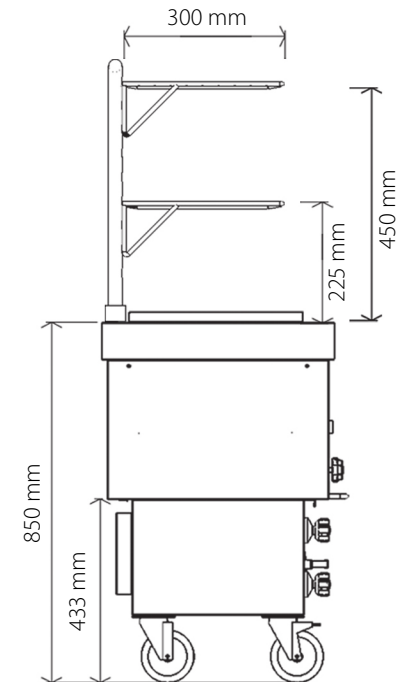
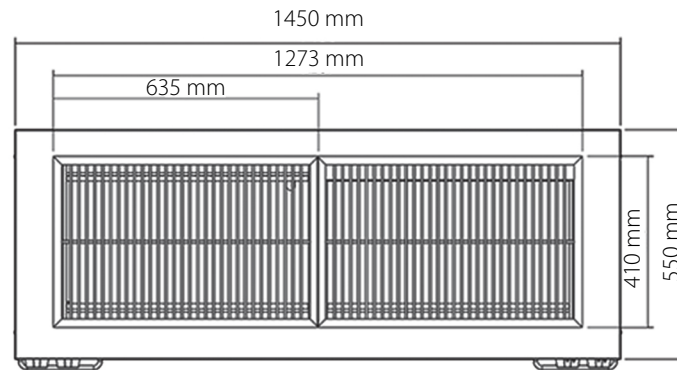
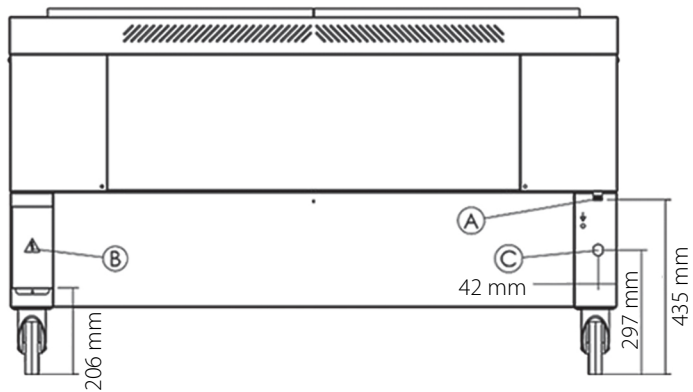
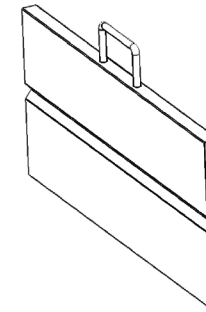

A - gas inlet 1/2" | B - power cord output | C - water inlet 3/4"
A - entrée de gaz 1/2" | B - sortie du cordon d'alimentation | C - arrivè d'eau 3/4"